

JOE

Design by Co. Studio

rvb[®]
Innovation since 1935

4586.--.97

Description Mitigeur de bain progressif sur pied, 2 fixations au sol, avec inverseur, flexible, douchette et support
Progressieve badmengkraan op voet, 2 vloerbevestigingen, slangen, handdouche en steun
Progressive bath mixer, freestanding with 2 floor fixings, with diverter, flexible, handshower and support

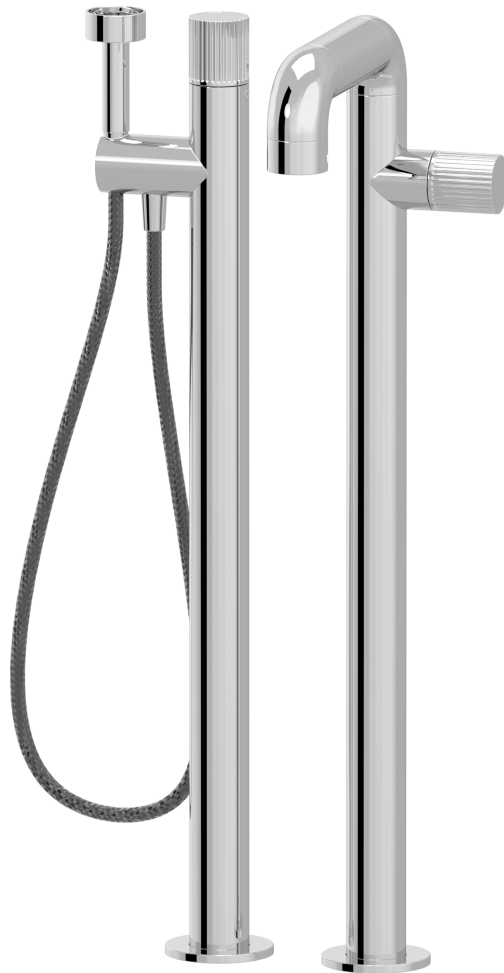

- FR** Instructions de montage et titre de garantie
- NL** Montagevoorschrift en garantiebewijs
- GB** Note of assembly and guarantee voucher

RAO.V01

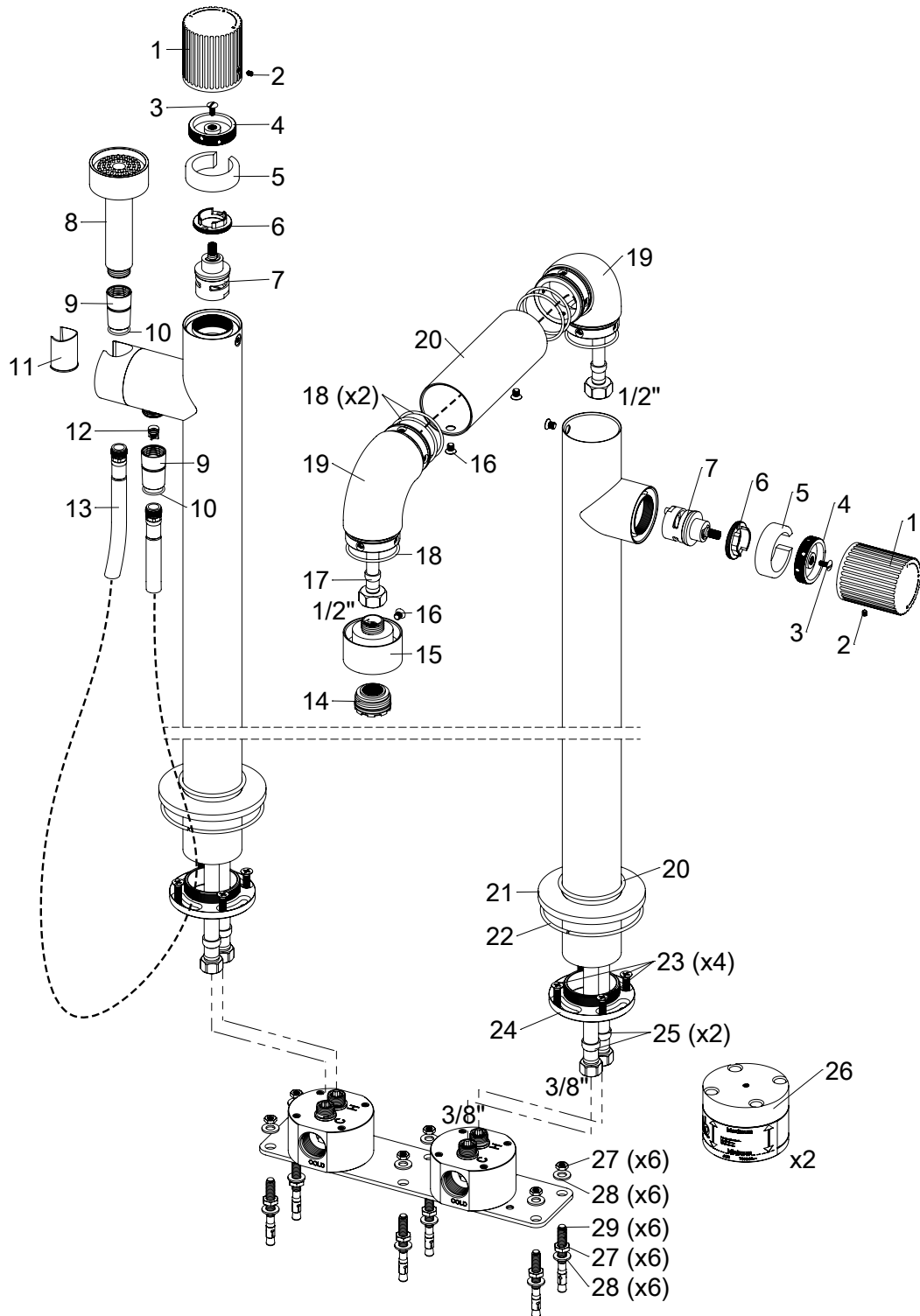

Picture

Product details

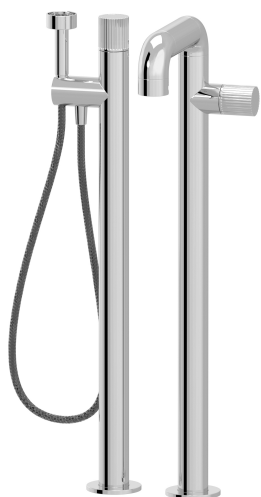

Internal mechanism : Ceramic valve progressive (x2)

Technical drawing

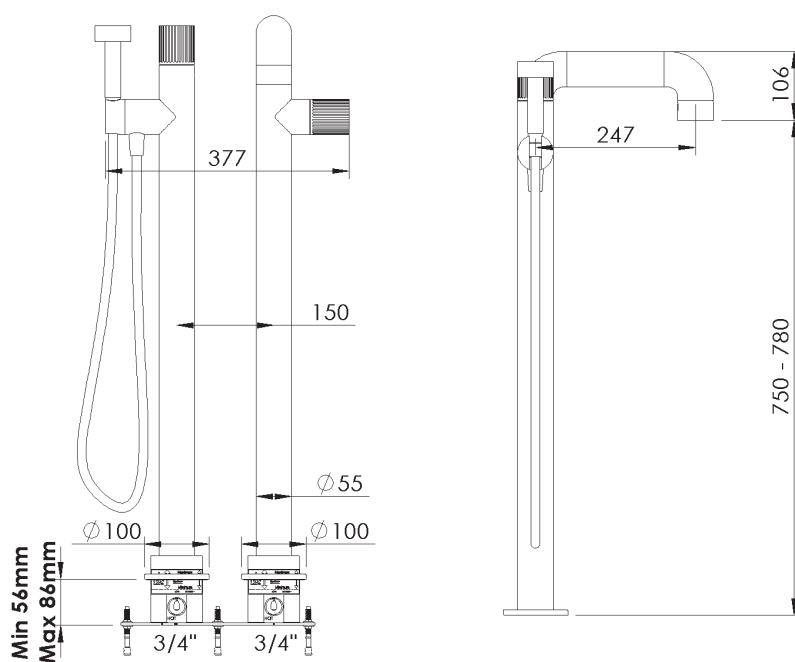

RA0.V01

Matériel fourni	Geleverd materiaal	Included material
-----------------	--------------------	-------------------

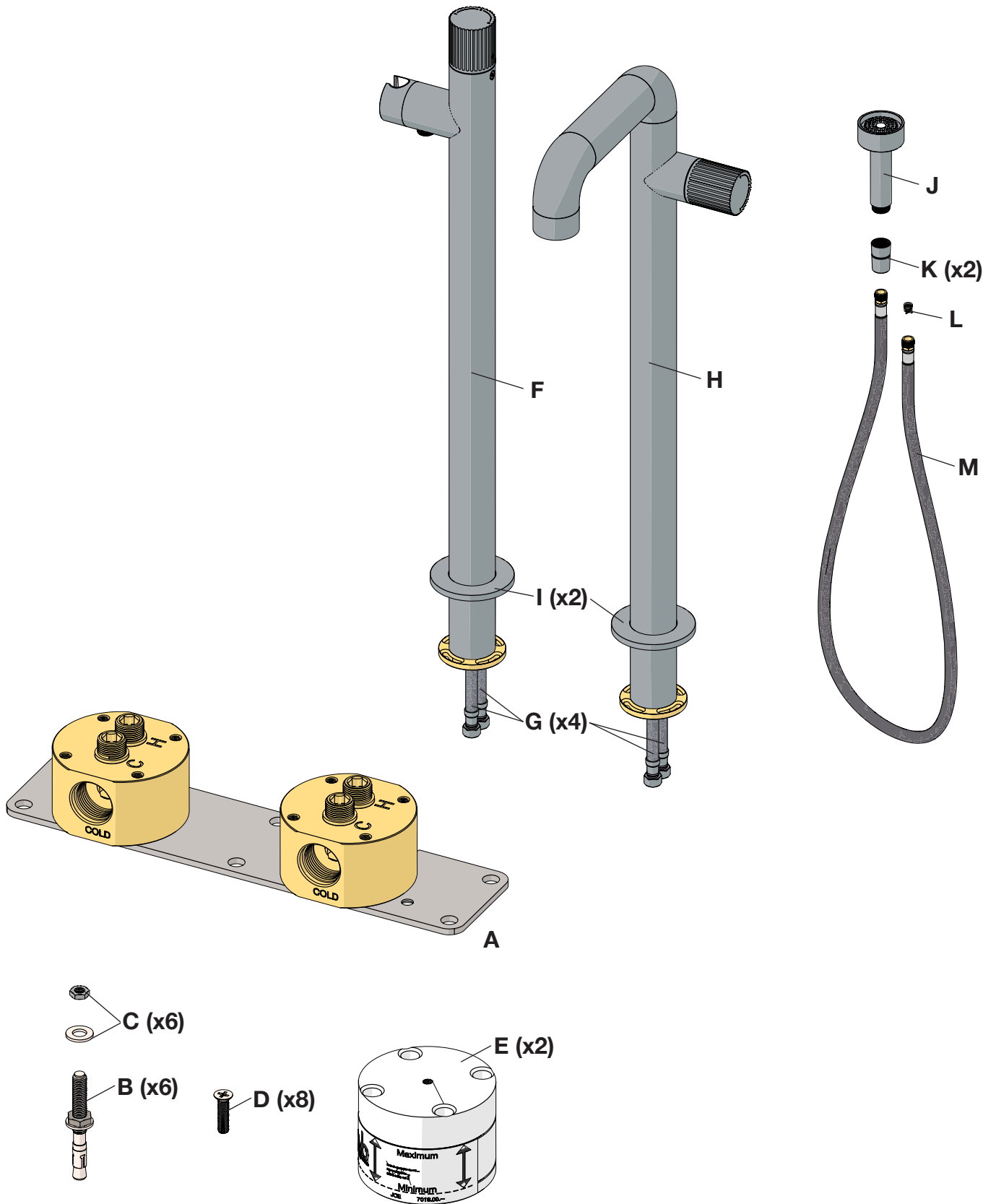

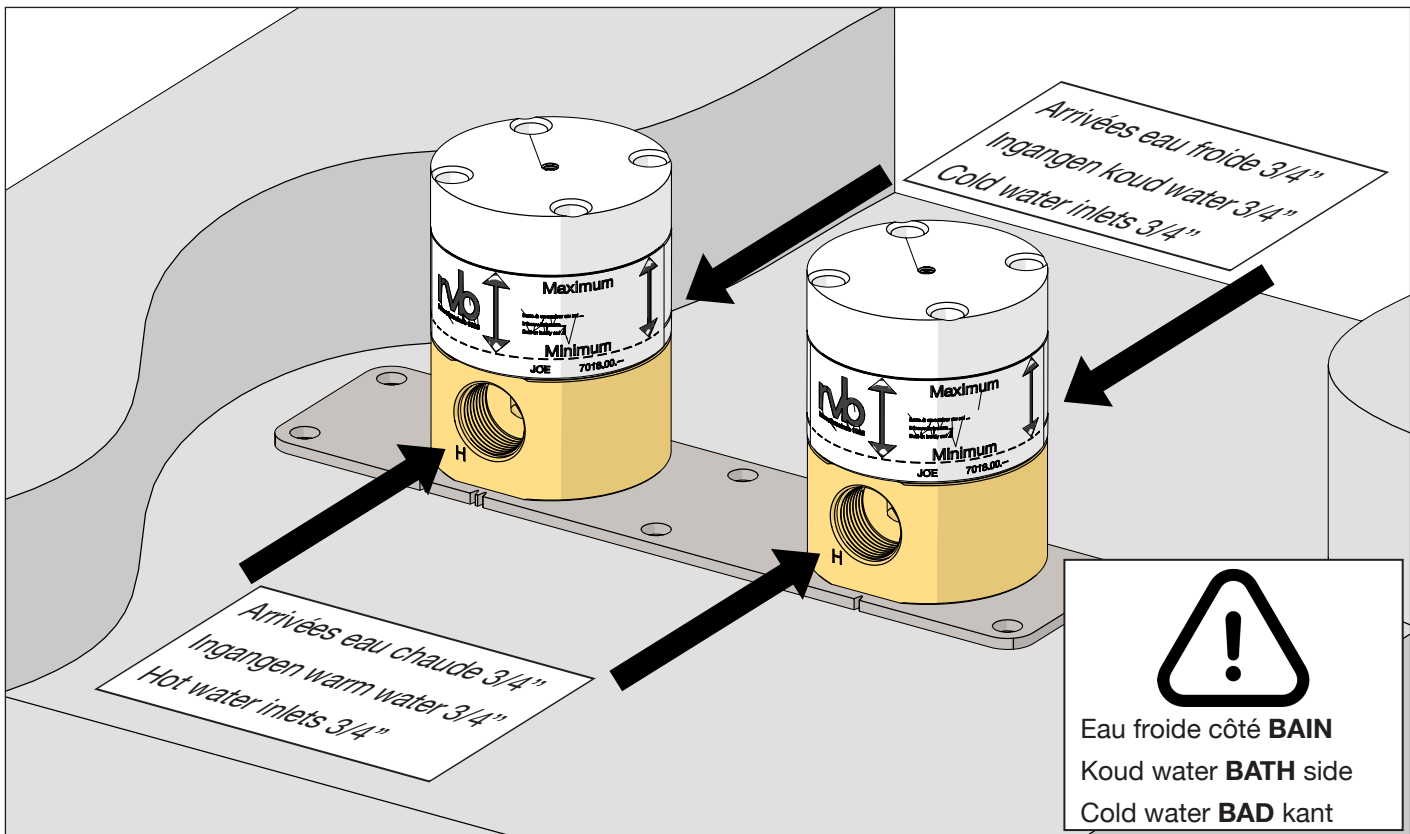
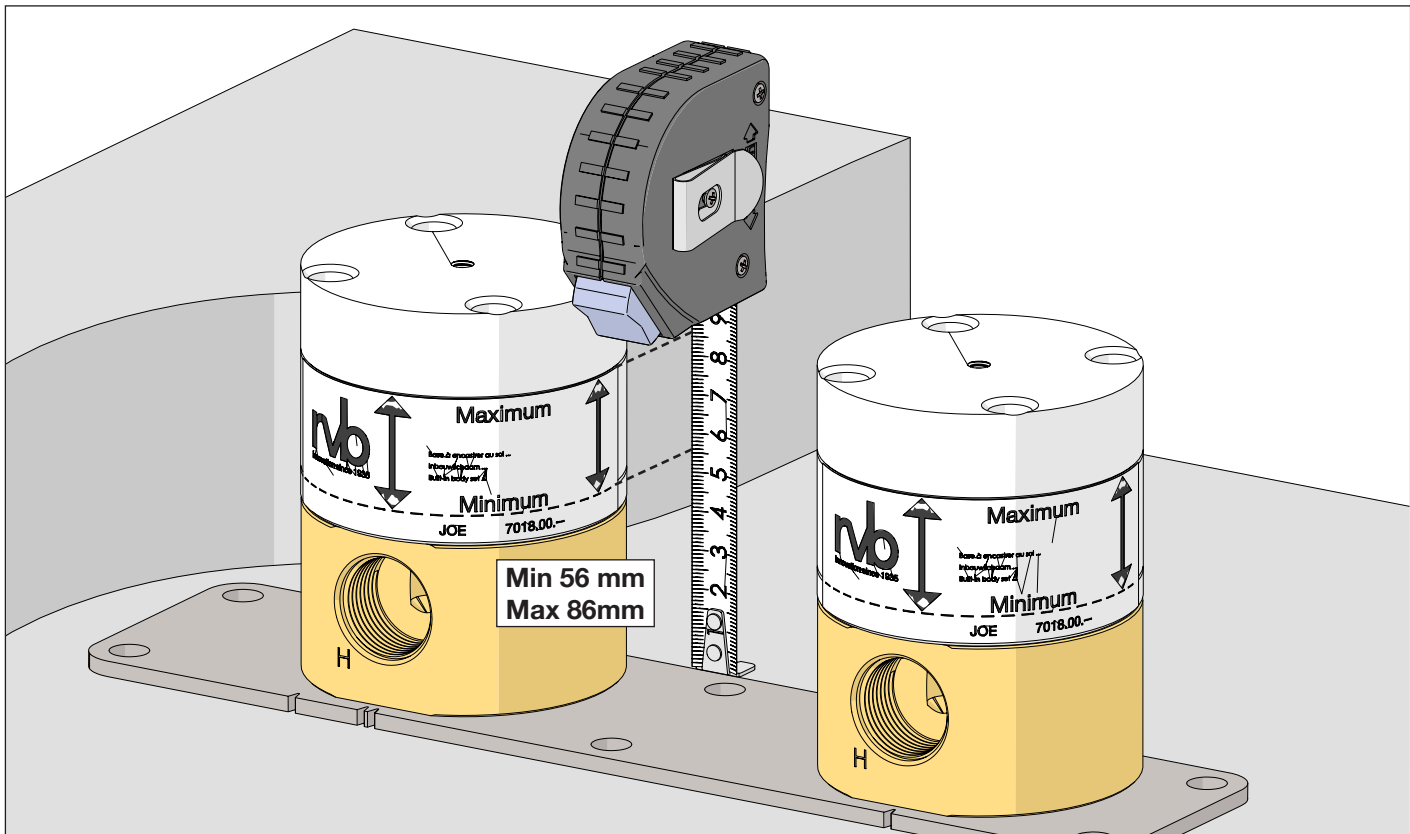

- Prévoir des conduites d'arrivée d'eau correctement dimensionnées pour garantir de bons débits.
 - Les instructions de montage doivent être respectées et suivies dans l'ordre.
 - Avant la mise en service de la robinetterie, le professionnel aura pris soin de purger les installations et de placer des filtres aux arrivées d'eau.
 - La pression d'installation doit être limitée à 5 bars.
 - Température d'arrivée d'eau chaude recommandée: 65 °C.
 - Pour l'entretien de la robinetterie se référer à la fiche «Recommandations d'entretien».
-
- Draag zorg voor een perfecte gedimensioneerde aanvoer van water om voldoende debiet te garanderen.
 - De montage instructies moeten gerespecteerd worden in de juiste volgorde.
 - Vóór de kranen in gebruik worden genomen moet de beroepsinstallateur de installaties spoelen en waterfilters plaatsen aan de toevoerleidingen.
 - De installatiedruk mag de 5 bar niet overschrijden.
 - Aanbevolen temperatuur bij ingang warm water: 65 °C.
 - Maak gebruik van de bijlage “ Raadgevingen voor onderhoud” voor het dagelijks onderhoud van het kraanwerk.
-
- The pipes must be properly sized to ensure good flow.
 - The installation instructions must be observed and followed in the right order .
 - Before the first use, the professional will have the installation purged and he will place filters to the water inlets.
 - The pressure should be limited to 5 bars
 - Inlet temperature of hot water recommended : 65 °C.
 - For servicing of the taps, refer to the page «Recommendations for care.».

RVB sa Boulevard Industriel 137 B-1070 Bruxelles Belgique

Tel: +32 (0)2 376 00 30 - Fax: +32 (0)2 332 08 54 - info@rvb.be - www.rvb.be

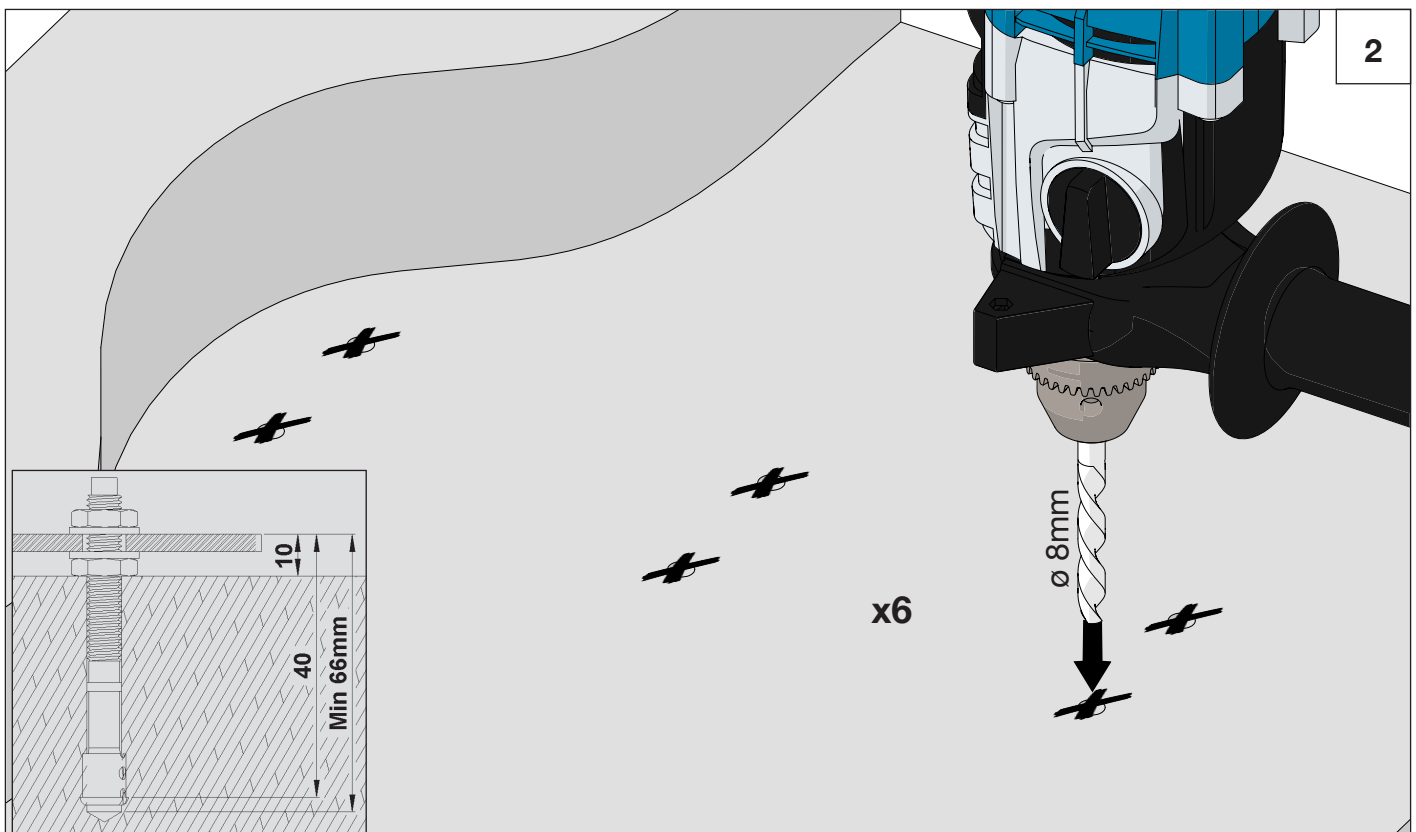
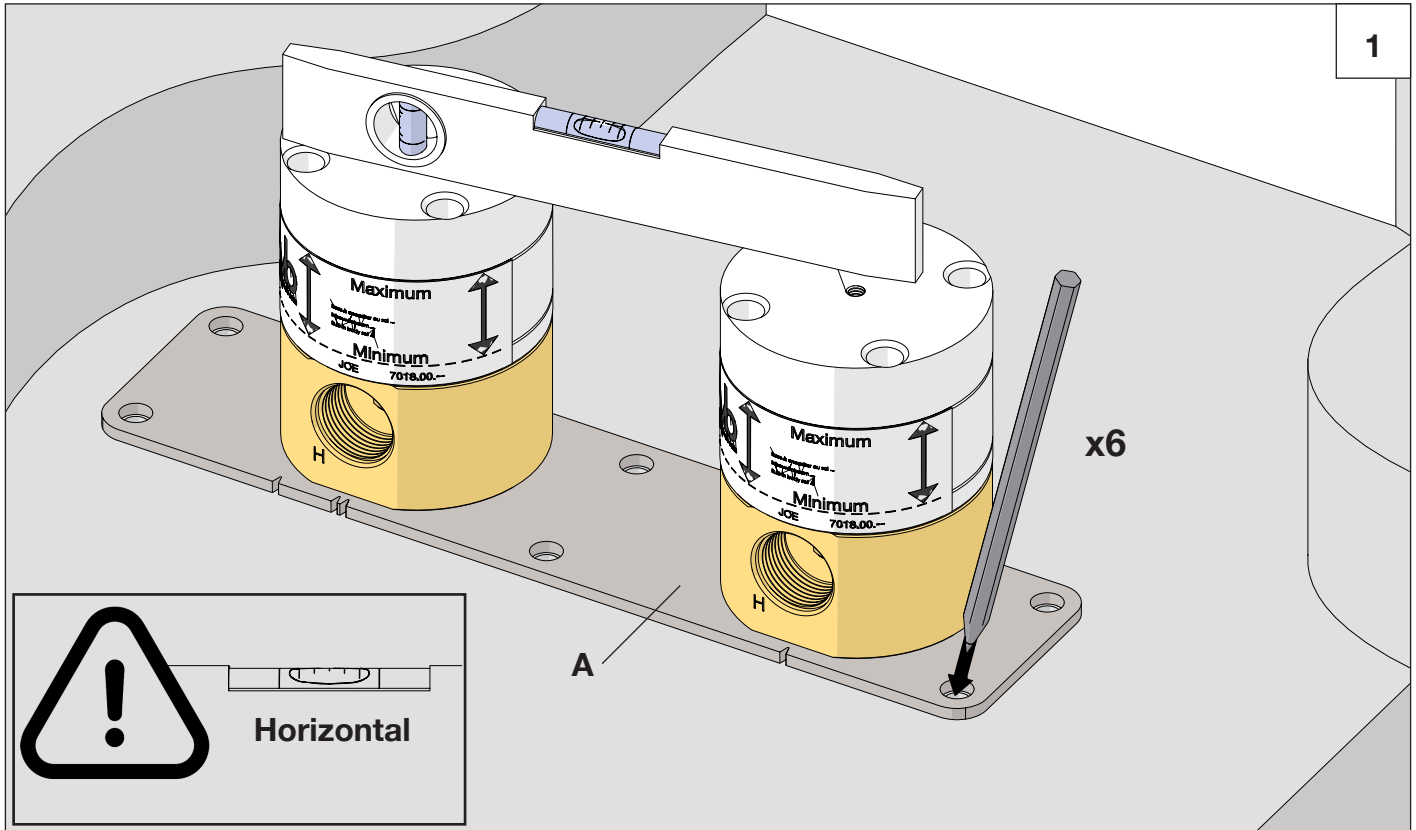

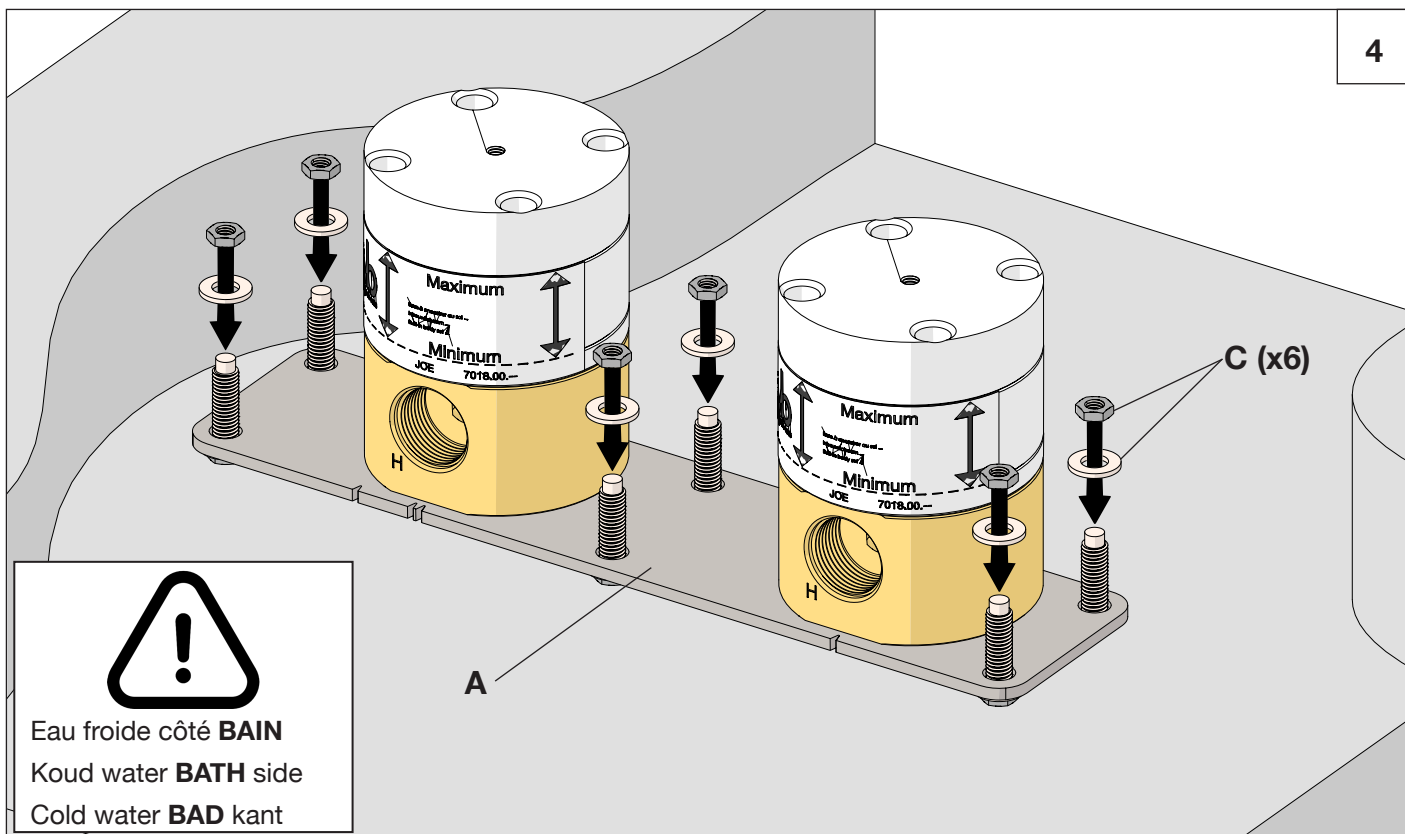
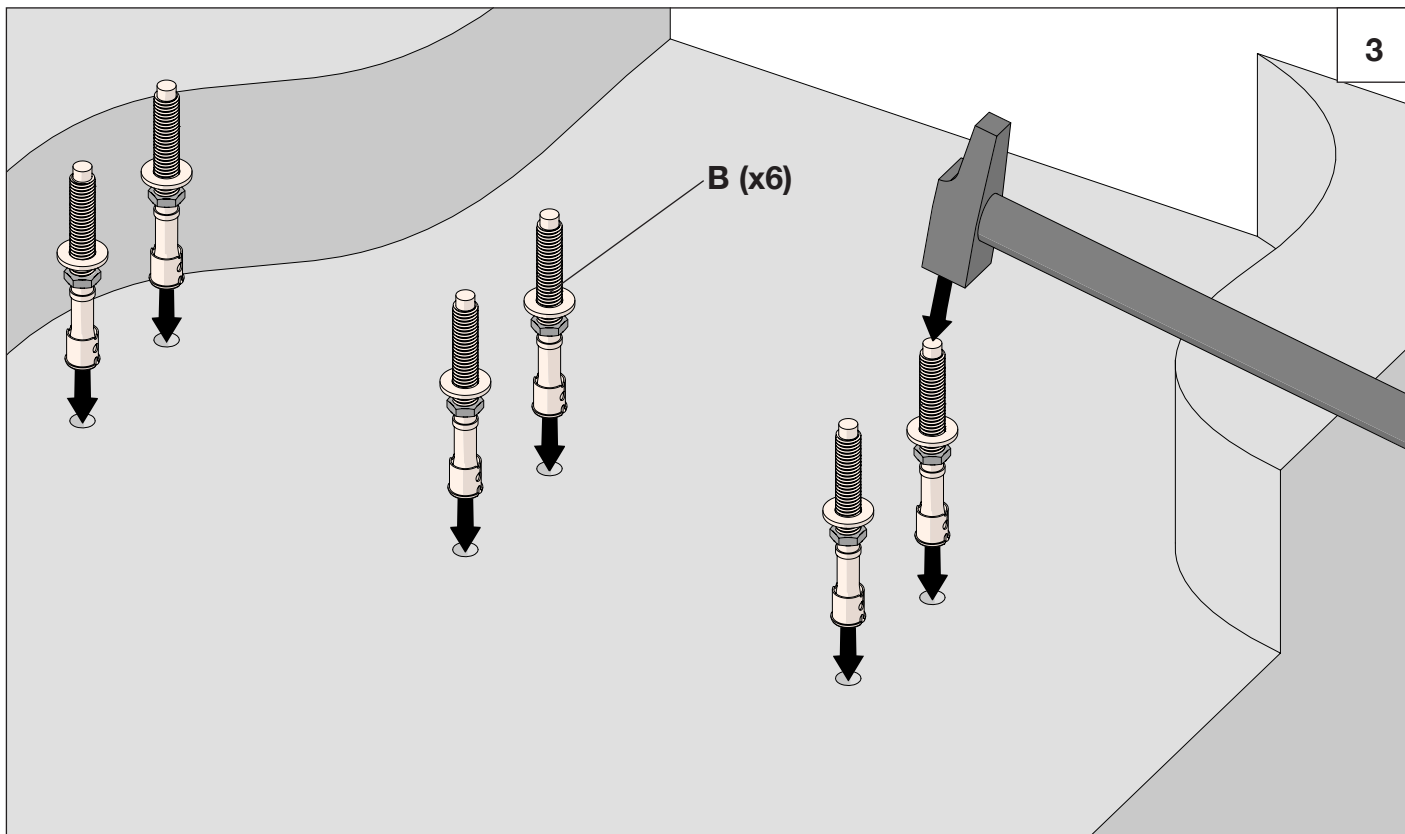

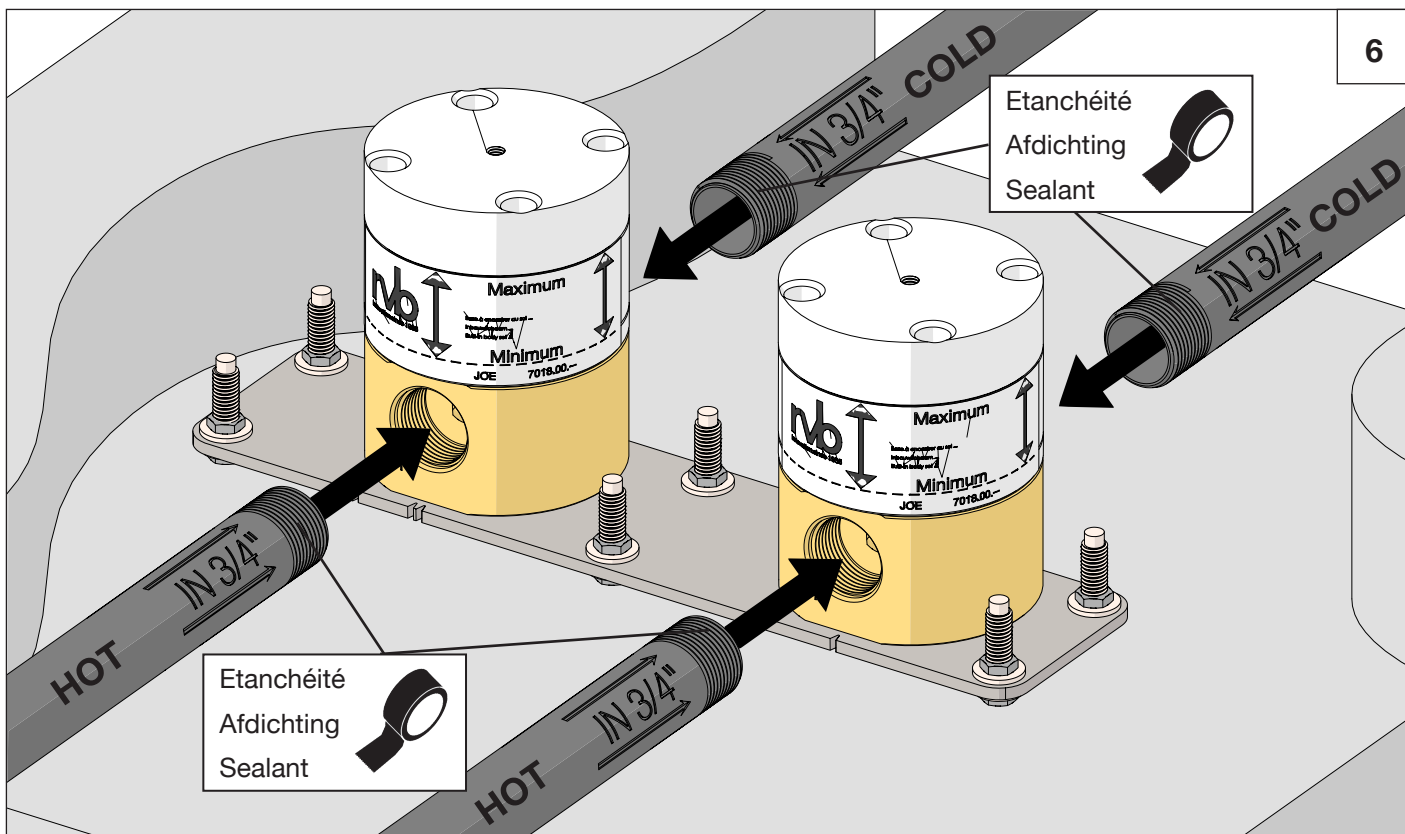
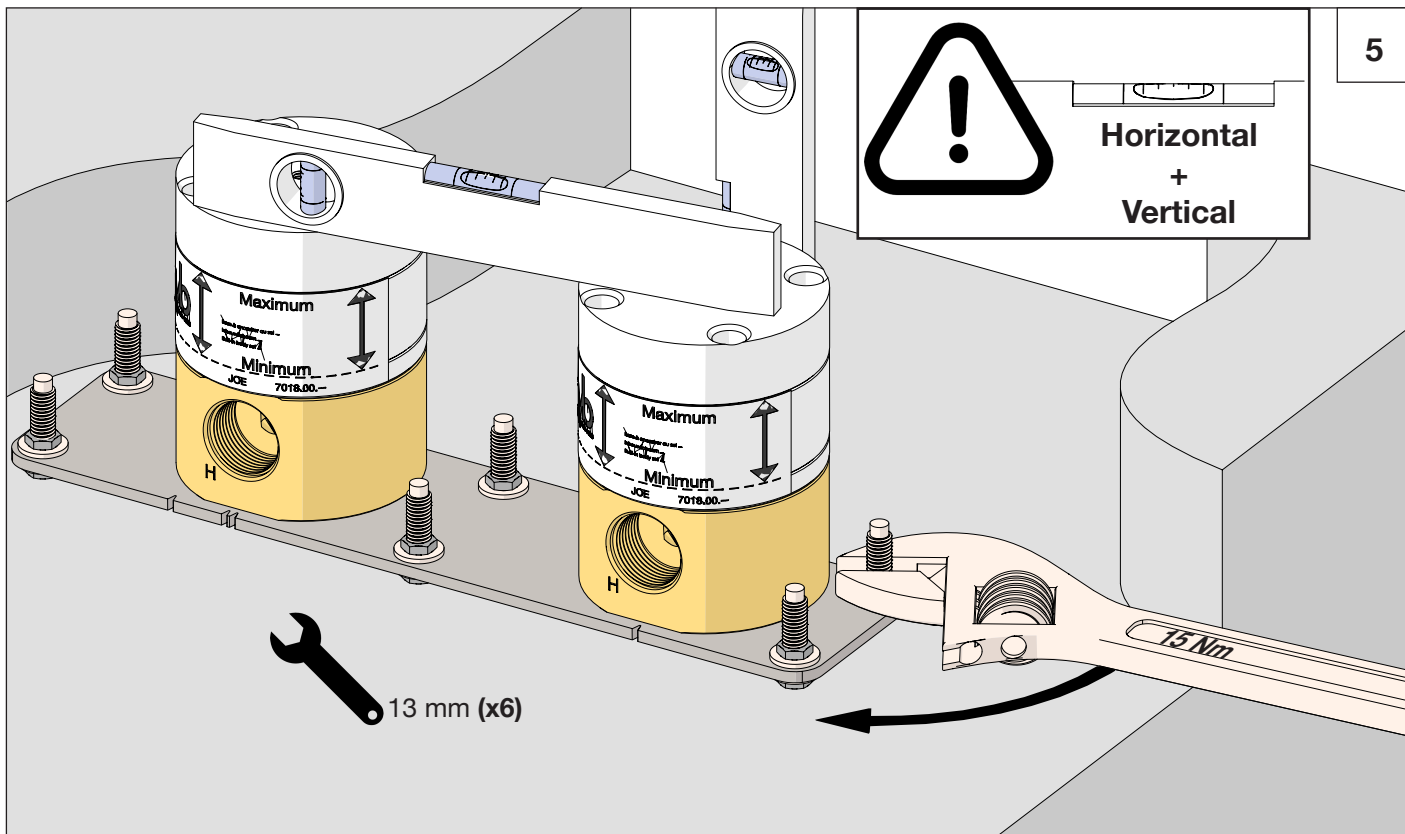

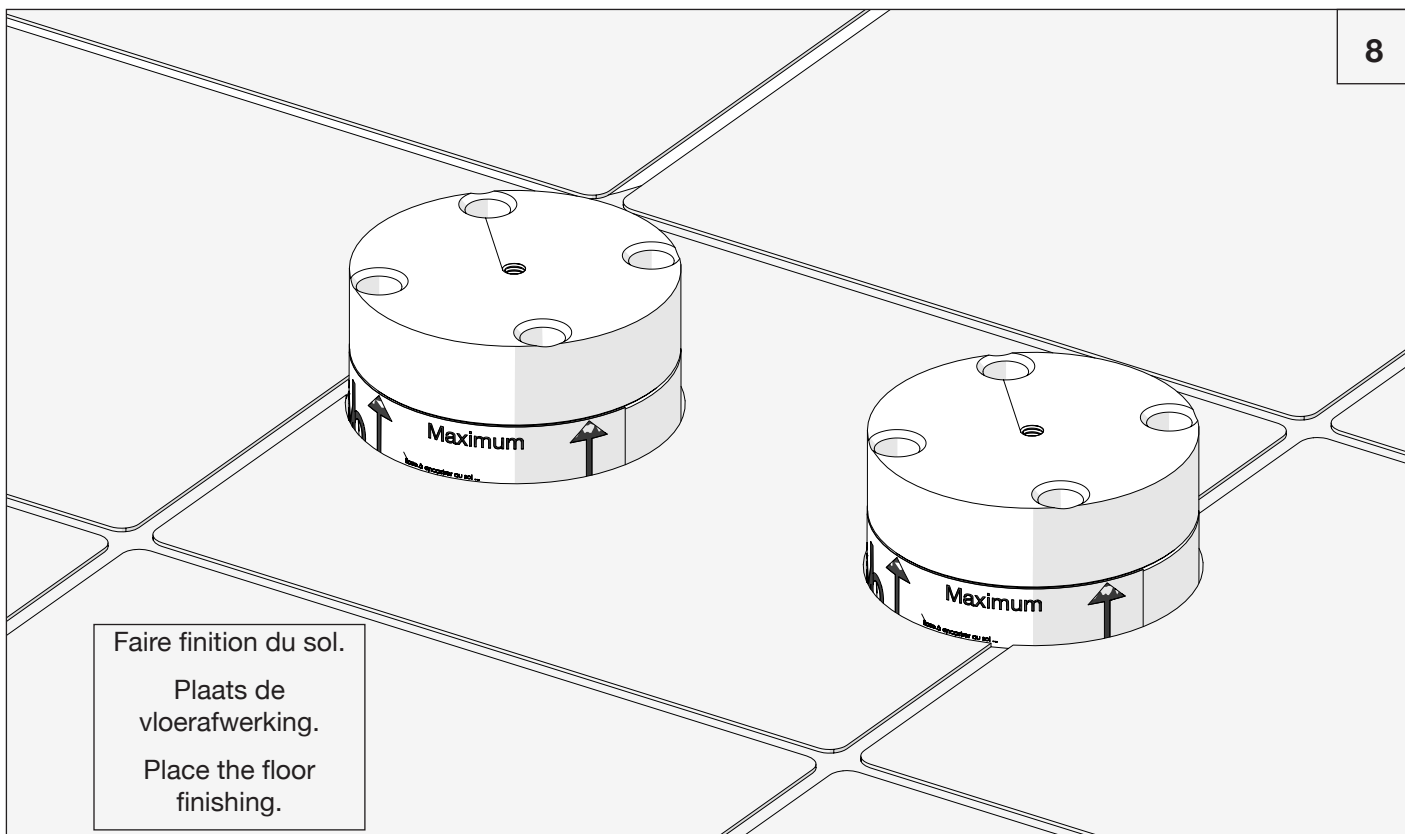
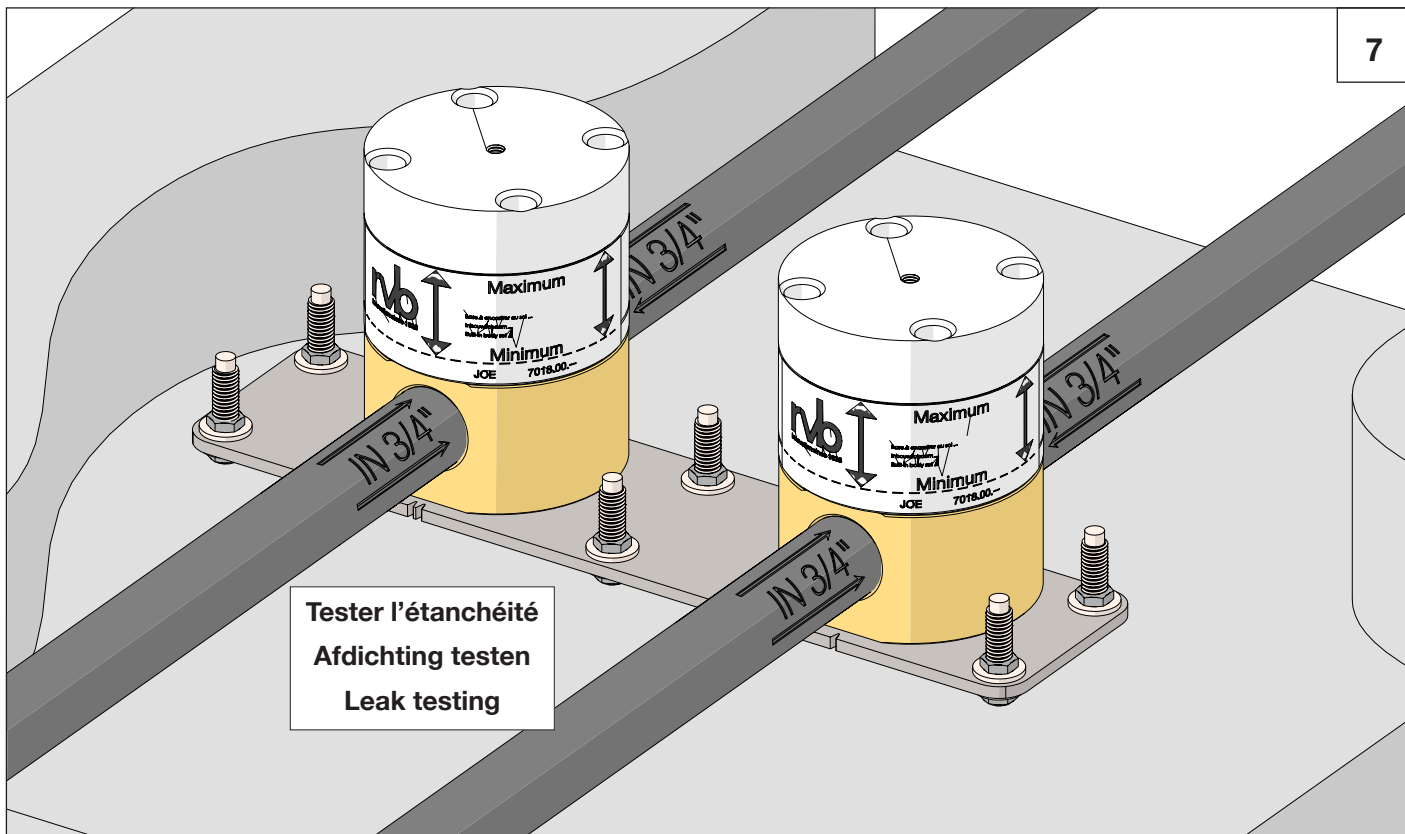

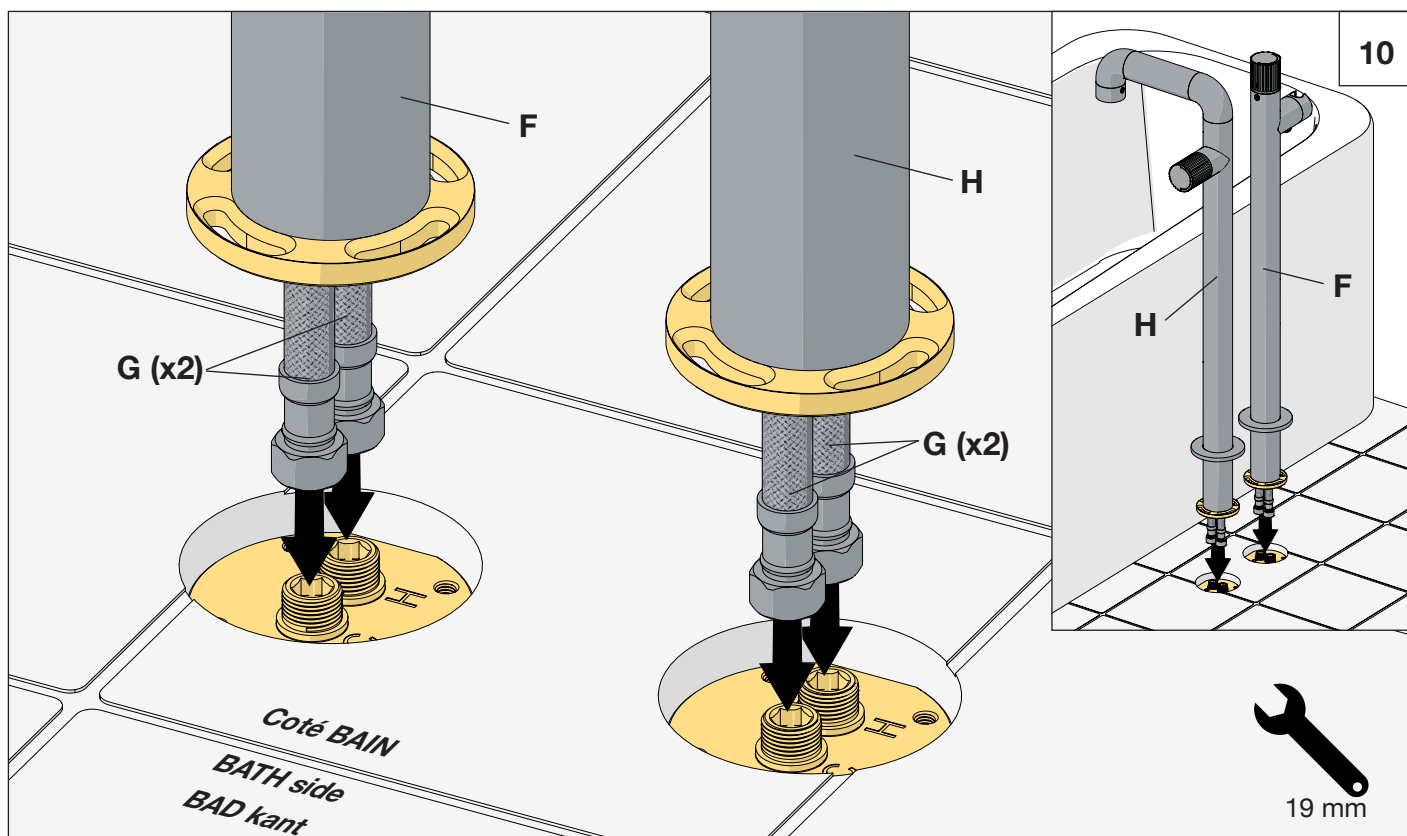
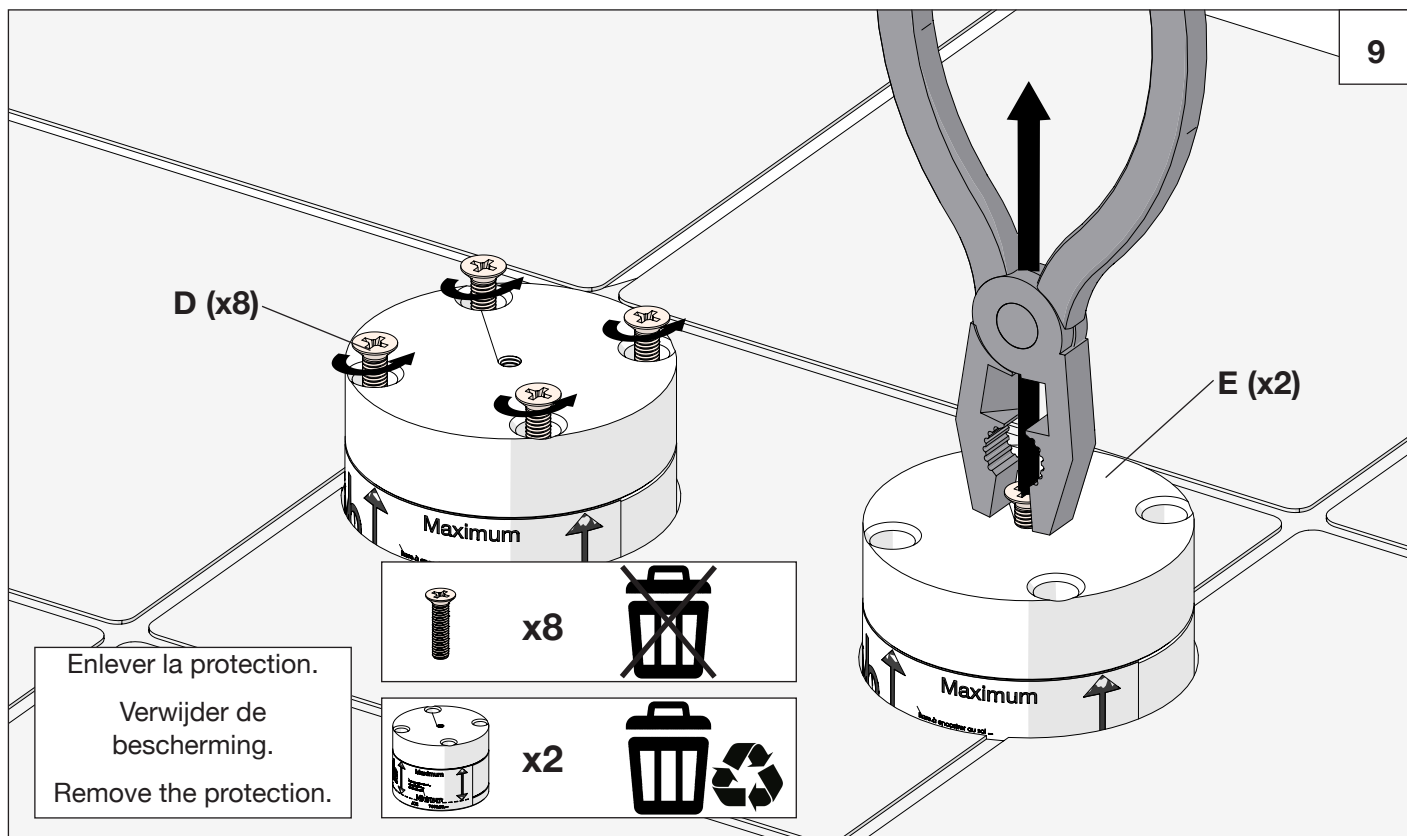

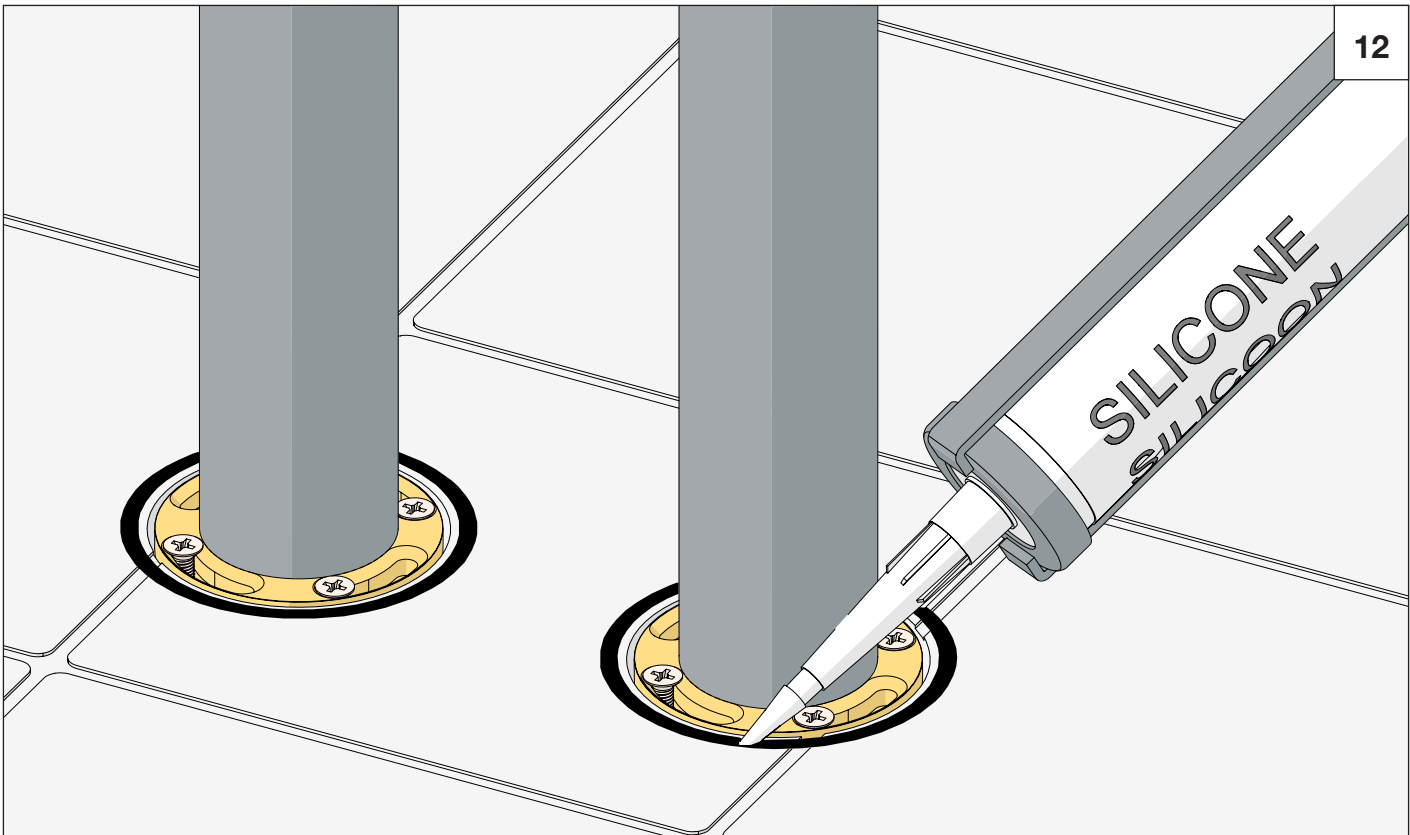
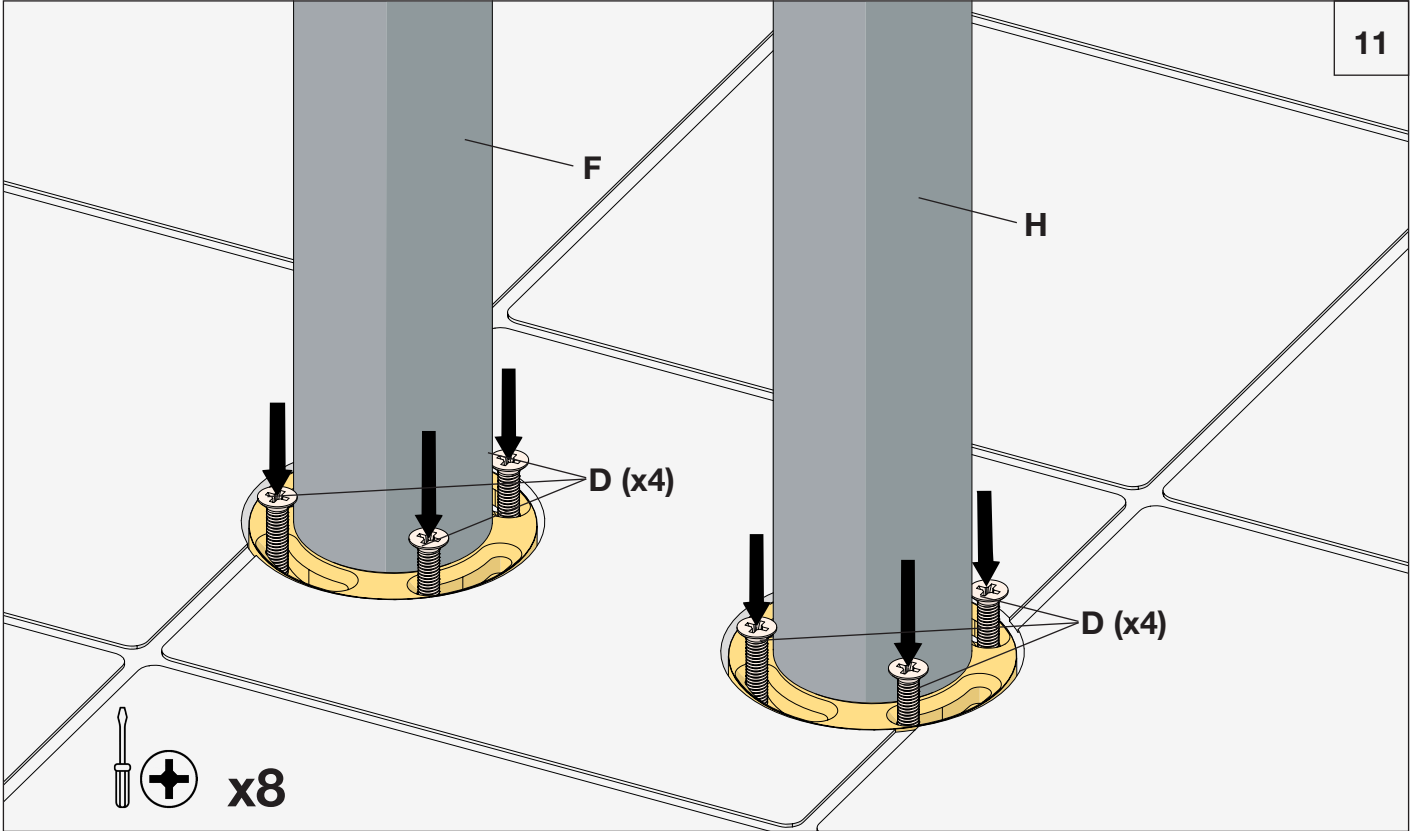

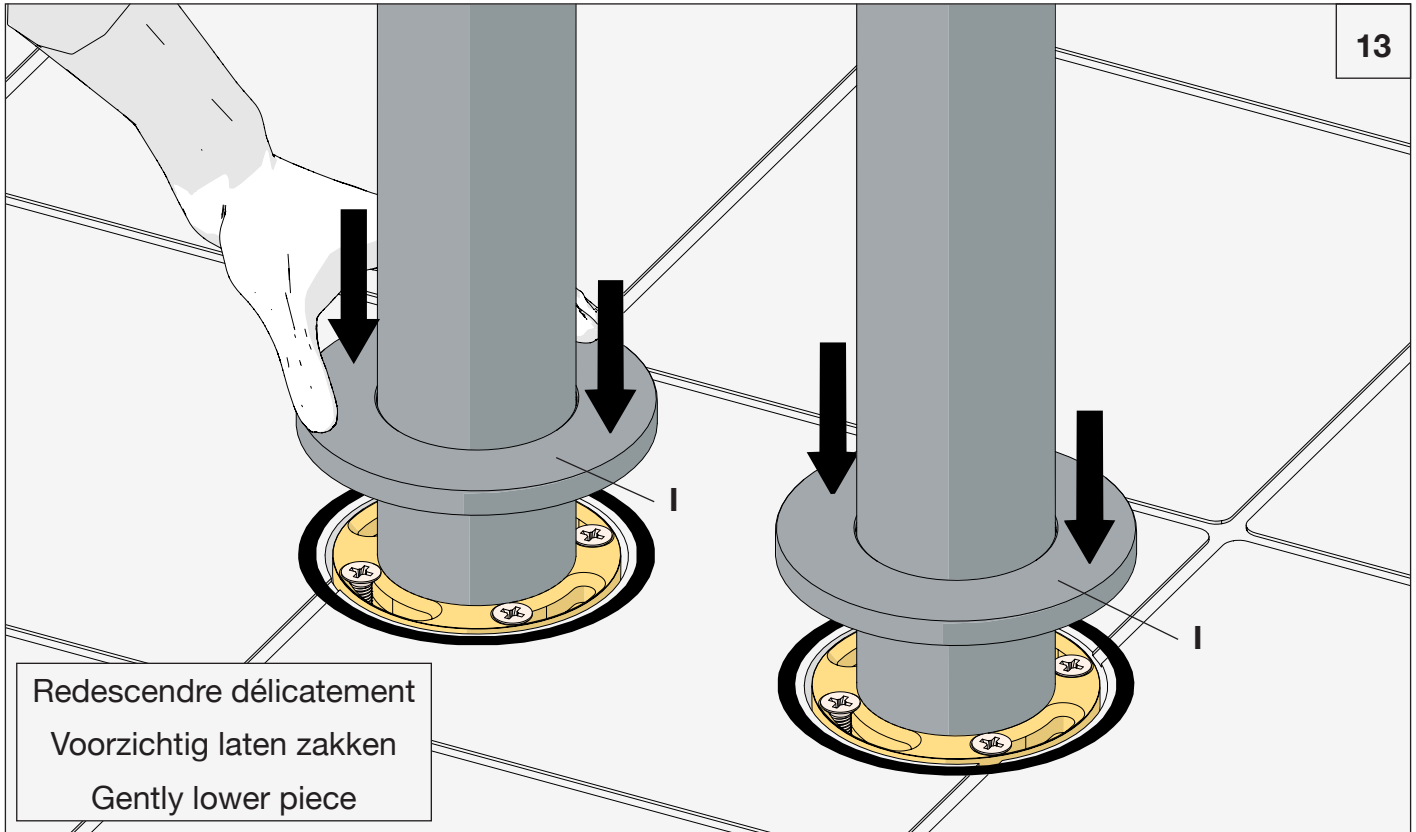

13

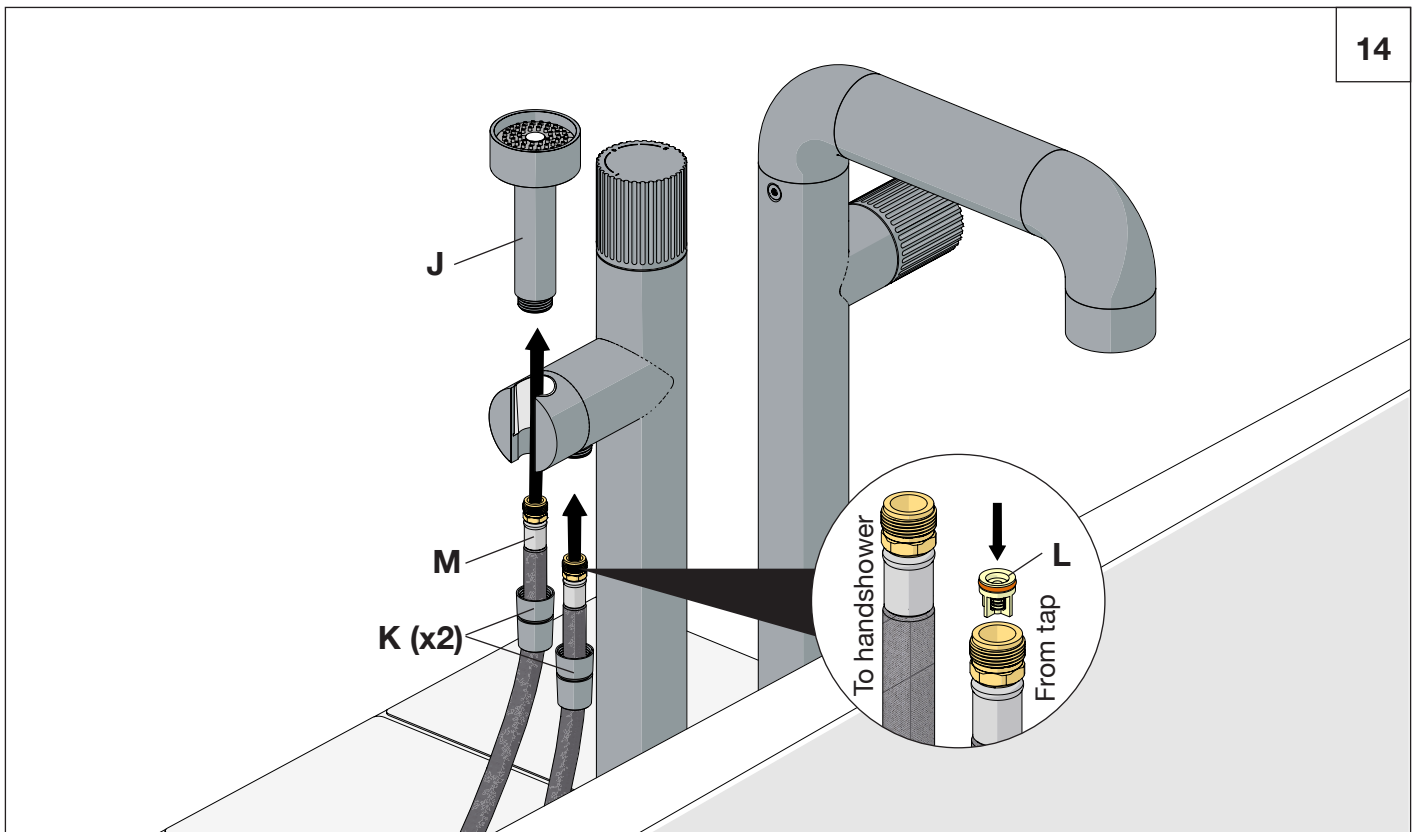

14

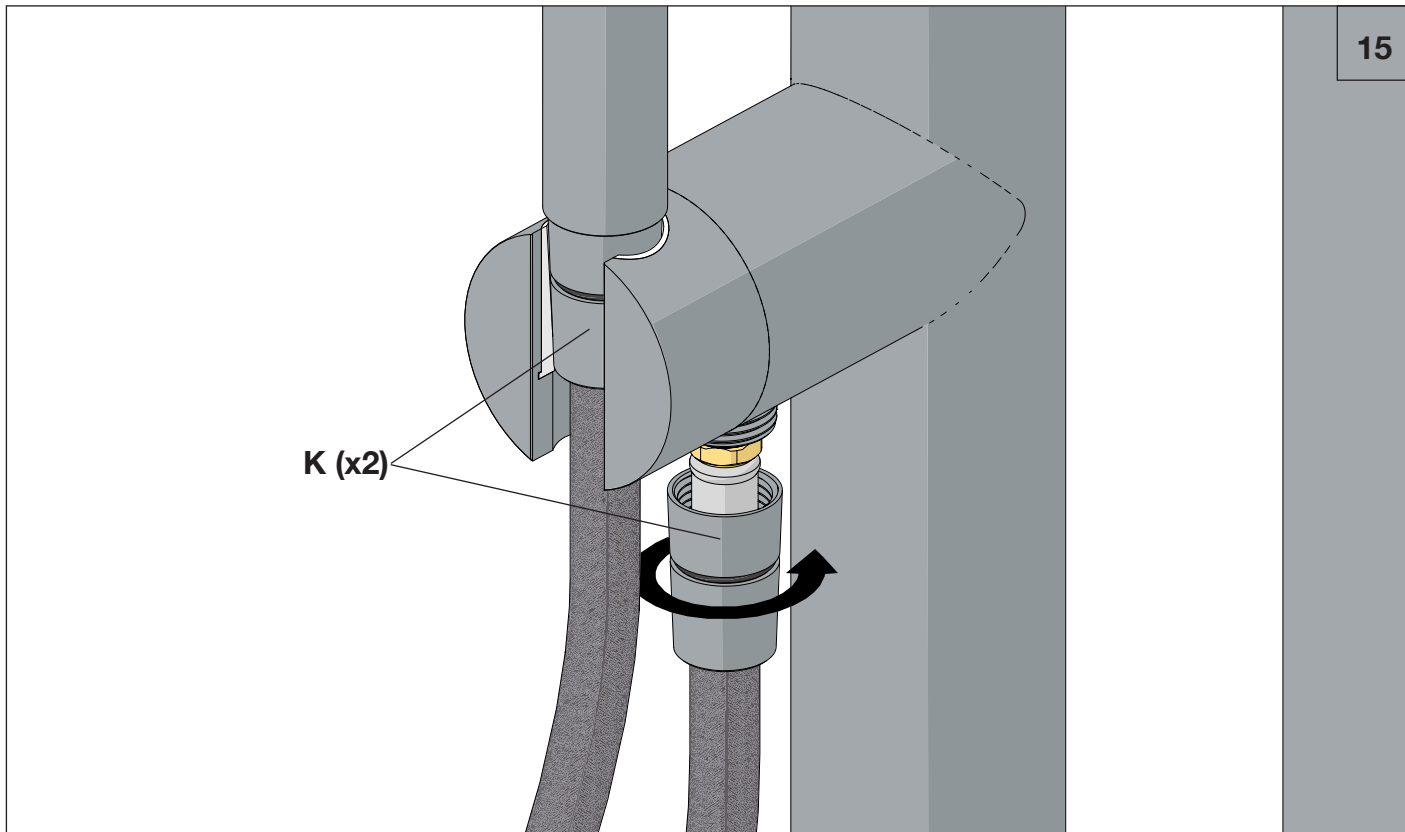

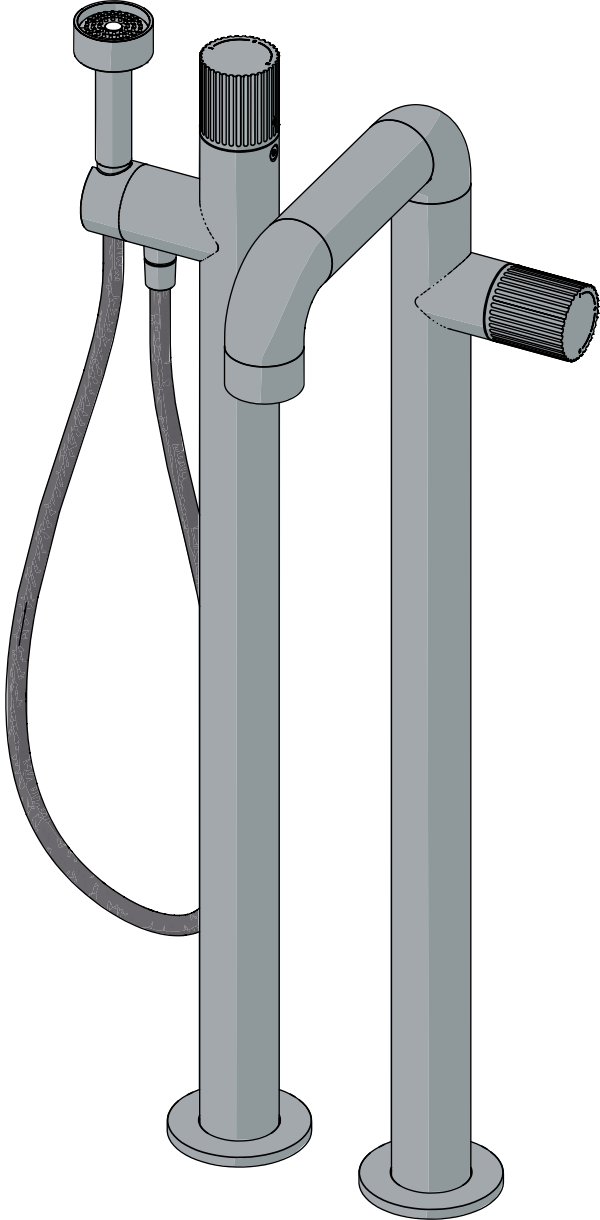



Innovation since 1935

Garantie

Garantie

Guarantee

F Votre titre de garantie repris sur la présente notice de montage ainsi que votre facture d'achat sont nécessaires pour revendiquer l'application de la garantie.

Conservez-les soigneusement. Voyez les conditions de garantie dans le folder «Entretien et Garantie des produits».

NL Om uw waarborg tot garantie te kunnen opeisen, is het noodzakelijk uw aankoopfactuur samen met uw garantiebewijs zorgvuldig te bewaren. Zie de garantie-voorwaarden in de folder «Onderhoud en waarborg van de producten».

GB Your guarantee voucher as your purchase invoice are necessary to claim the application of the guarantee. Preserve them carefully. You can find the guarantee conditions in the folder «Product Care and Guarantee».

4586.--.97